

RIVET SYSTEM™

Series 1, 4, and 6



Still need help? Give us a call at:
1-800-966-3999

Step 1 Build the base

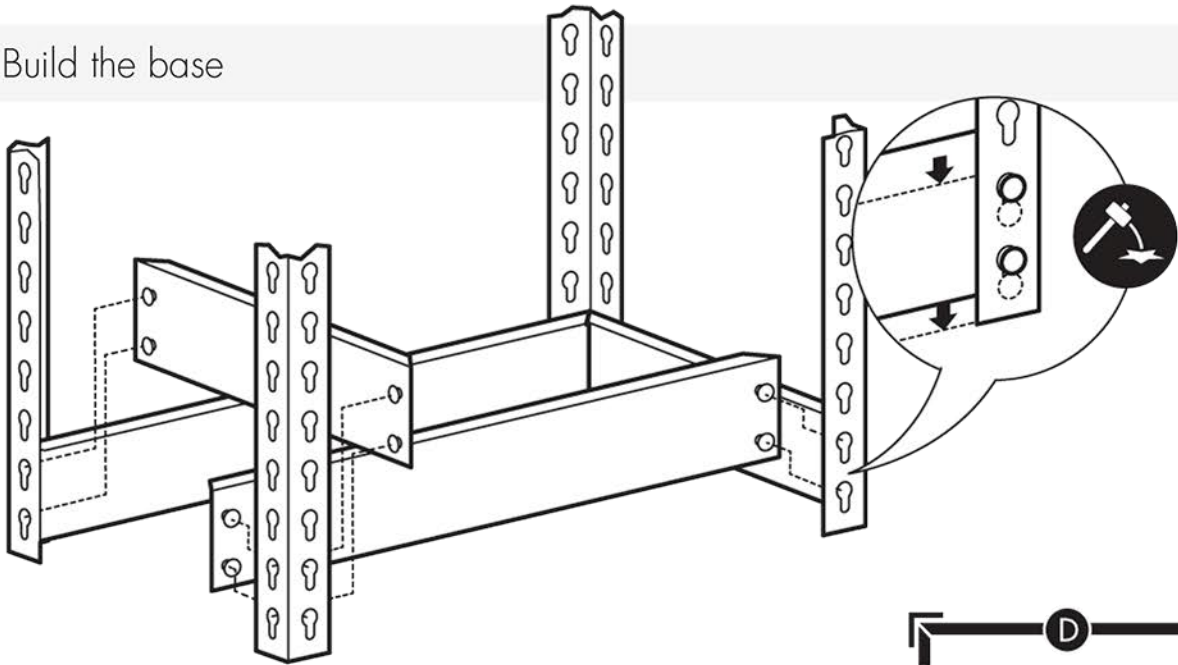

Note: Flange should be facing up on each beam when inserted into post, as the wood will lay on this flange.

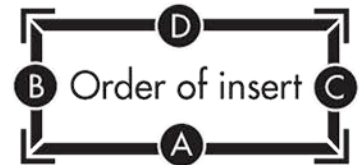

Step 2 Build the top

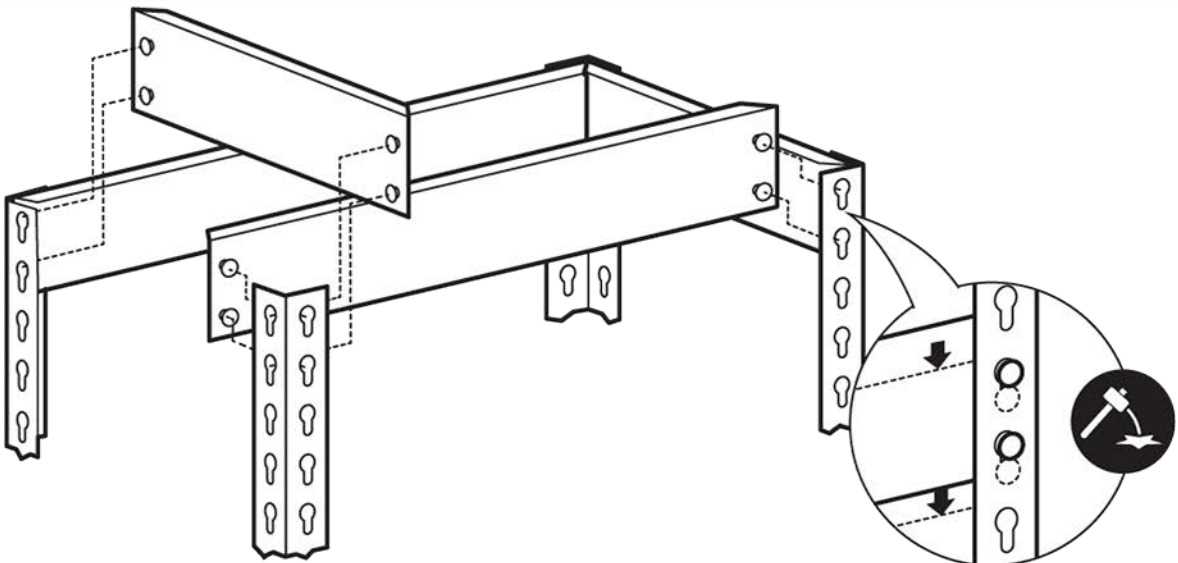

Step 3 Build the middle shelf

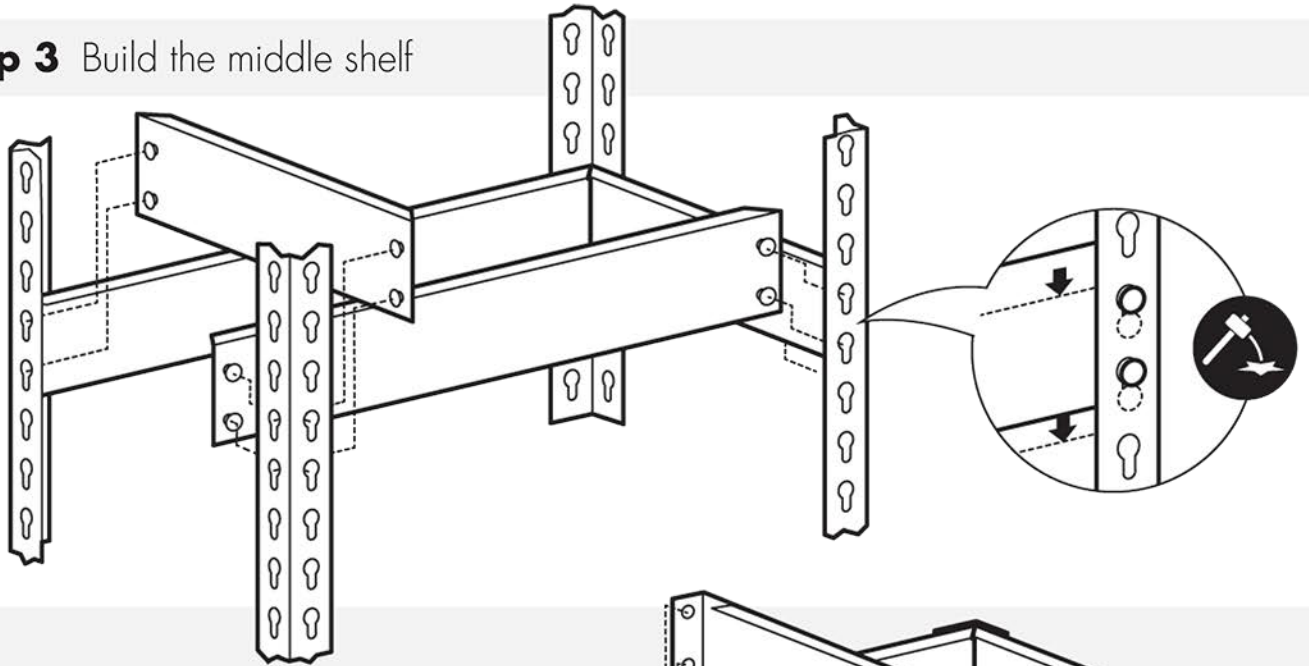

Note: There will be an additional step to install a shelf deck support in all Rivet System models containing the letter "H".

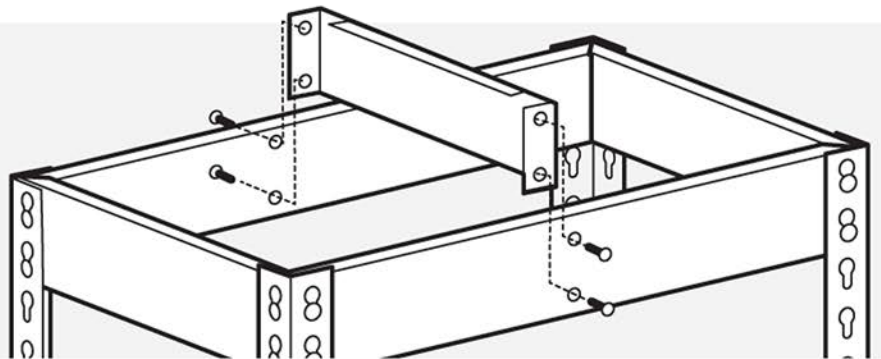

Step 4 Place the shelf board on top of each level

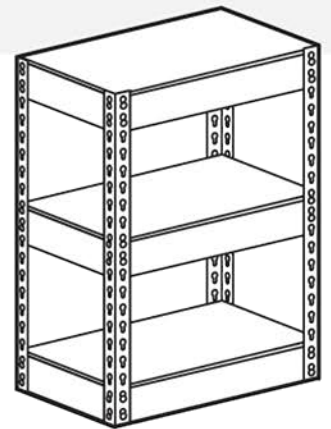
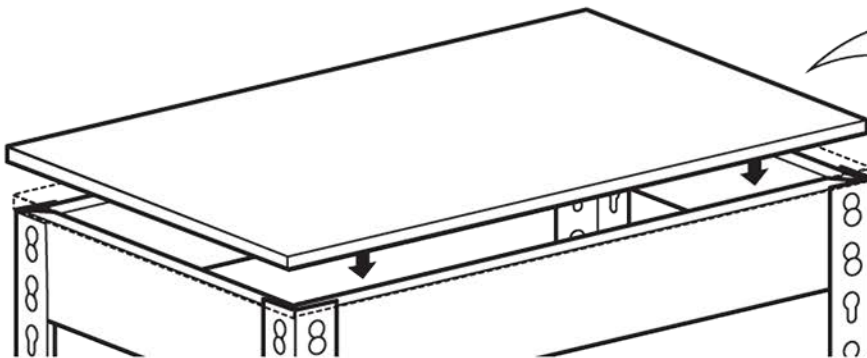

Space between each shelf in Inches

		number of shelves							
		3	4	5	6	7	8	9	10
height in ft	7	37,5	24	17,25	11	10,5	8,6	7,1	6
	8	43,5	28	20,25	15,6	12,5	10,3	8,6	7,3
	9	49,5	32	23,25	18	14,5	12	10,1	8,7
	10	55,5	36	26,25	20,4	16,5	13,7	11,6	10
	12	67,5	44	32,25	25,2	20,5	17,1	14,6	12,7

Numer of Rivet Holes between each shelf

		number of shelves							
		3	4	5	6	7	8	9	10
height in ft	7	25	16	12	11	7	6	5	4
	8	29	19	14	10	8	7	6	5
	9	33	22	16	12	10	8	7	6
	10	37	24	18	14	11	9	8	7
	12	45	29	22	17	14	11	10	8